

M3030ED

30-lb x 2 Capacity Stack Dryer

Standard Features:

- 30-lb. x 2 Capacity
- Residual Moisture Control (RMC)
- Single Phase Reversing
- Self-Diagnostic Microprocessor Control
- 100% Axial Airflow
- Completely Sealed Basket
- Non-Perforated Ribs and Basket
- Dual-Paned Door Glass
- Four-Point Roller Support System

Optional Features:

- Stainless Steel Front, Cabinet & Basket
- Single Phase Reversing
- F.S.S. (Fire Suppression System)

Why Purchase Milnor EcoDry?

100% Axial Airflow (standard)

EcoDry tumblers incorporate a 100% axial airflow design with a completely sealed basket. This ensures the most efficient drying available on the market today without sacrificing dry times.

Four-Point Roller Support System (standard)

EcoDryers are designed with a four-point roller support system, eliminating costly repairs and downtime due to trunnion failures.

Residual Moisture Control (standard)

EcoDry utilizes a unique Residual Moisture Control (RMC) sensing system to measure the presence of moisture in the load. The patented system senses when the load is dry, shutting the unit down to prevent over-drying. This saves time, utility costs as well as prolongs the life of dried items.

Available Option: Single Phase Reversing

Single Phase Reversing is an optional feature on the M3030ED. What once was an expensive option requiring an upgrade from single phase to three phase electrical service is now available in single phase. A reversing tumbler ensures that the load doesn't "rope" or "ball up", providing a quicker, more even drying process.

Your local Milnor independent authorized dealer.



M3030ED OPL Stack Dryer



M3030ED

M3030ED Specifications

Tumbler Capacity (dry weight per pocket)	30 lbs. (13 kg) x 2
Tumbler Diameter	25.75" (654 mm)
Tumbler Depth	34" (863 mm)
Tumbler Volume per pocket	10.25 cu ft (290 L)
Tumbler/Drive Motor per pocket	0.25 hp (0.19 kW)
Blower/Fan Motor per pocket	0.5 hp (0.37 kW)
Door Opening (Diameter)	19.37" (492 mm)
Door Sill Height top pocket / bottom pocket	49" (1244 mm) 13" (330 mm)
F.S.S. Water Connection	North America: 0.75"-11.5 NH Outside North America: 0.75" B.S.P.T.
Dryers per 20'/40' Container	14 / 28
Dryers per 48'/53' Truck	36 / 38
Width	27" (685 mm)
Depth	40.59" (1031 mm)
Height	72.87" (1851 mm)
Airflow per pocket	310 cfm (8.78 cmm)
Exhaust Connection	6" (152 mm)
GAS MODEL:	Approx. Net Wt. 535 lbs (242 kg) Approx. Ship Wt. 560 lbs (254 kg) Heat Input 52,500 btu/hr (13,230 kcal/hr) Inlet Pipe Connection per pocket (CE and Australia Only) 0.37" M.N.P.T. / 0.37" M.B.S.P.T.

* Not available in electric or steam models.
** Specifications in parentheses are metric equivalents.

REV 6/11/13

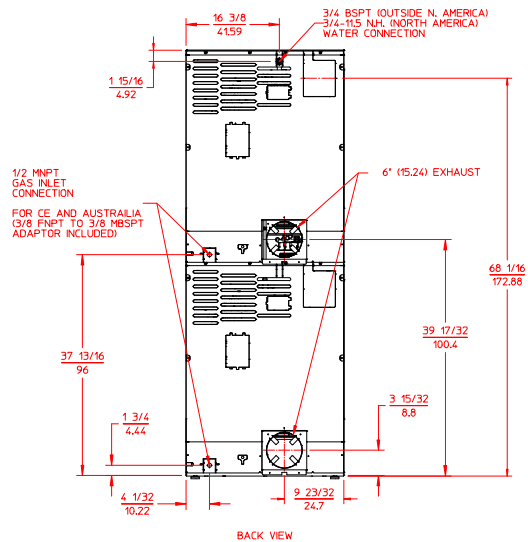
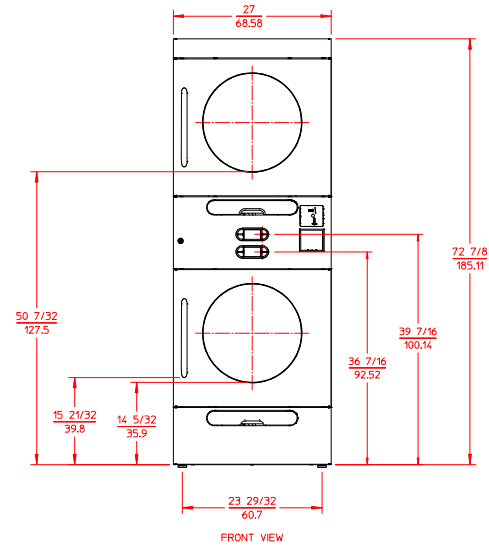

Electrical Service Specifications					
SERVICE VOLTAGE	PHASE	WIRE SERVICE	APPROX AMP DRAW		CIRCUIT BREAKER
			60 Hz	50 Hz	
GAS					
120	1ø	2	8.9	--	15
200	1ø	2	7.7	7.8	15
208	1ø	2	7.6	--	15
220	1ø	2	7.3	7.4	15
230	1ø	2	--	7.3	15
240	1ø	2	7.2	7.0	15

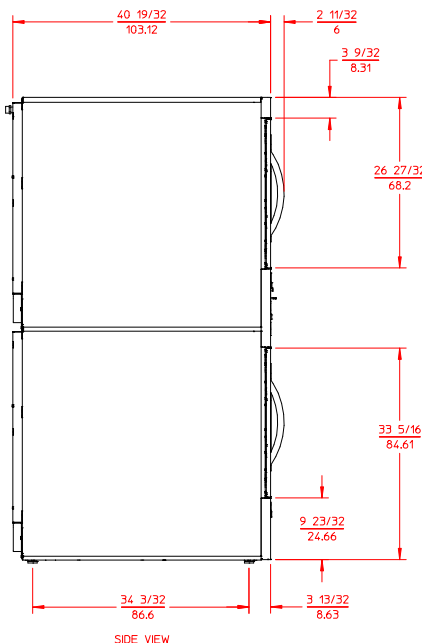

BACK VIEW

